



# K&E TOOLS

Division of Railhead Corporation  
10721 S. Western Ave. ~ Chicago, IL 60643-3135  
Phone 773-779-2400 ~ Fax 773-779-0231  
[www.ketools.com](http://www.ketools.com)

## MODEL KE-1100 3/4" Square Drive Impact Wrench JUMBO HAMMER



### SPECIFICATIONS:

Bolt capacity..... 1"  
Working Torque.....200-750 ft. lbs  
Maximum Torque.....1100 ft. lbs.  
Speed..... 5,500 R.P.M.  
Impacts per minute .....770  
Weight.....12 3/4 lbs.  
Length.....7 5/8"  
Hose Size .....1/2"  
Air consumption.....9.5 C.F.M.  
Air inlet thread size.....3/8" N.P.T.  
Air pressure.....90 P.S.I.

### IMPORTANT:

**OIL DAILY. FIRST IN THE  
MORNING AND JUST BEFORE  
END OF DAY. USE A GOOD  
GRADE SPINDLE OIL OR  
SPECIAL AIR MOTOR OIL.**

### OPERATING & MAINTENANCE:

1. Use of filter and lubricator assembly is recommended to insure proper functioning and long life.
2. The grease in the impact mechanism should be changed after every 40 hours of operation.
3. Before starting tool in operation, blow hose out prior to attaching to the tool to prevent dirt and water from entering tool.
4. If a bolt or nut can not be loosened or tightened to proper torque after five seconds of impacting, a larger size wrench is needed for the job. This is an indication of:
  - a. Low air pressure or volume.
  - b. Improper application of wrench.
  - c. Worn out socket.
5. Do not use sockets that are too large for the capacity of the tool. This will wear or break the square drive spindle prematurely.
6. Check rotor blades for wear in the event the tool is gradually losing power and all other operating conditions are proper.

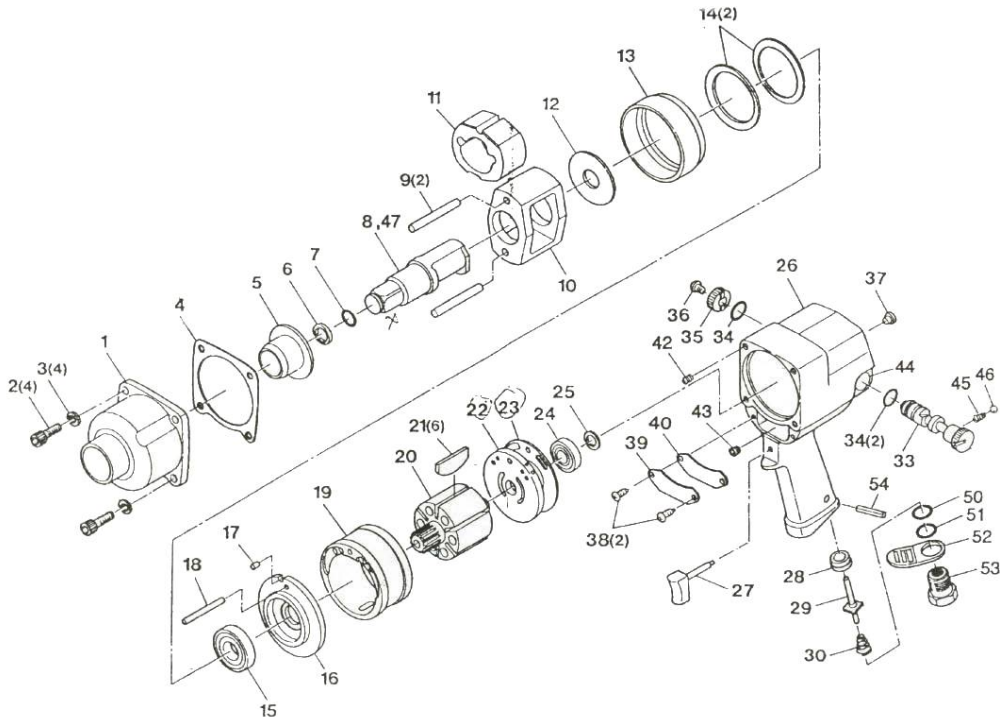

REF. #	NUMBER	PART NAME	QTY	REF. #	NUMBER	PART NAME	QTY
1	15801	HAMMER CASE	1	27	15827	TRIGGER	1
	15801COM	HAMMER CASE CP		28	15828	THROTTLE VALVE SEAT	1
2	15802	CAP SCREW	4	29	15829	THROTTLE VALVE	1
3	15803	WASHER	4	30	15830	THROTTLE VALVE SPRING	1
4	15804	HAMMER CASE GASKET	1	33	15833	REVERSE VALVE	1
5	15805	HAMMER CASE BUSHING	1	34	15834	REVERSE VALVE SEAL	2
6	15806	RETAINING RING	1	35	15835	REVERSE VALVE KNOB	1
7	15807	O RING	1	36	15836	REVERSE VALVE KNOB SCREW	1
8	15808	ANVIL SHANK TWIN HAMMER	1	37	15837	GREASE FITTING	1
	15808	ANVIL SHANK JUMBO	1	38	15838	HOUSING PLATE SCREW	2
9	15809	HAMMER PIN	2	39	15839	HOUSING PLATE	1
10	15810	HAMMER FRAME	1	40	15840	HOUSING PLATE GASKET	1
11	15811	HAMMER	1	42	15842	HEIL COIL (INCL:26)	4
12	15812	WASHER	1	43	15843	PLUG (INCL: 26)	1
13	15813	MOTOR RETAINER	1	44	15844	REVERSE VALVE BUSHING (INCL:26)	1
14	15814	MOTOR CLAMP WASHER	2	45	15845	SPRING	1
15	R-14	BALL BEARING	1	46	15846	STEEL BALL	1
16	15816	FRONT END PLATE	1	47	15847	LONG ANVIL SHANK	1
17	15817	DOWEL PIN	1				
18	15818	CYLINDER PIN	1	15849	15849	DEAD HANDLE BRACKET	1
19	15819	CYLINDER	1	50	S-20	O RING	1
20	15820	ROTOR	6	51	15851	O RING	1
21	15821	ROTOR BLADE	1	52	15831	EXHAUST DEFLECTOR	1
22	15822	REAR END PLATE	1	53	15832	SWIVEL INLET BUSHING	1
		REAR END PLATE GASKET	1	54	15854	ROLL PIN	1
23	15823	REAR END PLATE GASKET	1				
24	R-10	BALL BEARING	1				
25	15825	RETAINER RING	1				
26	15826	MOTOR HOUSING	1				